

**RRRB - JE**



**CIVIL**

**Railway Recruitment Board**

**Volume - 12**

**Environmental Engineering**



# WATER DEMAND & RESOURCES

## THEORY

### 1.1 | WATER DEMAND

#### 1.1.1 Domestic Water Demand

The total domestic water consumption usually vary from 50% to 60% of the total water supply to a city. The IS code list down a limit of water consumption between 135 to 225 ltr/capita/day (LPCD). Under ordinary condition (as per IS code) the domestic water demand for a town or a city with full flushing system should be taken as 200 LPCD. Although it can be reduced to 135 LPCD for economical weaker section and LIG colony.

#### 1.1.2 Industrial Water Demand

This quantity varies with number and type of industries present in the city. This consumption under ordinary condition is 50 LPCD. Some industries influence a high water demand like : Paper industry, Textile industries etc.

#### 1.1.3 Institutional and Commercial Water Demand

On an average demand is 20 LPCD. It may be as high as 50 LPCD.

#### 1.1.4 Demand for Public Use

This includes water requirement for parks, gardening washing of roads etc. On this account a normal amount not exceed 5% of consumption may be provided.

#### 1.1.5 Fire Demand

The quantity of water require for fire is not very large. The city upto 50 lakh population hardly amount is 1 LPCD. But this water should be easily available and kept always stored in storage reservoir.

#### 1.1.6 Water Demand for Losses & Theft

This may be as high as 15% of total demand.

### 1.2 | FACTORS AFFECTING WATER DEMAND

- |  |   |
|--|---|
| (a) Size of city                         | (b) Climate condition                     |
| (c) Industrial and commercial activities | (d) Habits of people                      |
| (e) Quality of water supply              | (f) Pressure in the distribution system.  |
| (g) Development of sewage facility.      | (h) Cost of water and method of charging. |

### 1.3 | POPULATION FORECASTING METHODS

Methods are based on laws of probability and growth curve. Following are population forecasting methods :

- |   |  |
|---|--|
| (a) Arithmetic increase method          | (b) Geometric increase method                |
| (c) Incremental increase method         | (d) Decreasing rate of growth method         |
| (e) Simple graphical method             | (f) Comparative graphical method             |
| (g) Master plan method or zoning method | (h) The ratio method or apportionment method |
| (i) The logistic curve method           |  |

*Methods are Discussed Below:*

#### (a) Arithmetic Increase Method

This method assumes that the population increases at a constant rate :

$$\frac{dP}{dt} = \text{constnat}$$

Forecasted population ( $P_n$ ) after 'n' decades

$$P_n = P_0 + n\bar{x}$$

where,

$P_0$  = Population at last known census.

$\bar{x}$  = Average (Arithmetic mean) of population increase in last decades.

n = No. of decades between last census and future.

#### (b) Geometric Increase Method

It is also known as 'uniform increase method'.

Forecasted population,

$$P_n = P_0 \left(1 + \frac{r}{100}\right)^n$$

where,

$P_0$  = Population at last known census.

r = Growth rate (%)

$r = \frac{\text{Increase in population}}{\text{Orginal population}} \times 100$  for each decade.

Knowing as  $r_1, r_2, r_3, r_4, \dots, r_n$  for each decade.

The average value of r can be found by

##### (i) Arithmetic average method

$$r = \frac{r_1 + r_2 + r_3 + \dots + r_n}{n}$$

##### (ii) Geometric average method

$$r = (r_1 \times r_2 \times r_3 \dots \times r_n)^{\frac{1}{n}}$$

*Note: Engineers adopt arithmetic average method since it gives more value than the geometric avg. Method. However GOI manual on water supply recommends 'Geometric mean method'.*

**(iii) Incremental increase method:**

Rate of growth is not assumed constant.

Population

$$P_n = P_0 + n\bar{x} + \frac{n(n+1)}{2}\bar{y}$$

where,

$P_0$ ,  $n$ ,  $\bar{x}$  are as usual.

$\bar{y}$  = Average of Incremental increase of the known decades.

**Note:** (i) Geometric mean method suitable for younger cities expanding of faster rate.

(ii) Incremental increase method suitable for both old and new cities.

**Example:** The population of 5 decades from 1930 to 1970 are given below in table. Find out the population after '3' decades beyond the last known decade, by using

(i) Arithmetic mean method      (ii) Geometric mean method      (iii) incremental increase method

Year	1930	1940	1950	1960	1970
Population	25000	28000	34000	42000	47000

**Solution:**

Col (1)	Col (2)	Col (3)	Col (4)	Col (5)
Year	Population	Increase in population	Growth rate (r) %	Incremental increase
1930	25000			
		3000	$\frac{3000}{25000} \times 100 = 12$	
1940	28000			6000-3000 = 3000
		6000	$\frac{6000}{28000} \times 100 = 21.4$	
1950	34000			8000-6000 = 2000
		8000	$\frac{8000}{34000} \times 100 = 23.5$	
1960	42000			5000-8000 = -3000
		5000	$\frac{5000}{42000} \times 100 = 11.9$	
1970	47000			
Total		$\Sigma = 22000$		$\Sigma = 2000$

**(i) Arithmetic mean method:**

$$\bar{x} = \frac{\sum \text{col(3)}}{4} = \frac{22000}{4} = 5500$$

$$P_{2000} = P_{1970} + n\bar{x}$$

$$= 47000 + 3 \times 5500 = \mathbf{63500}$$

**Ans.**

**(ii) Geometric mean method :**

(a) 
$$r = \frac{r_1 + r_2 + r_3 + r_4}{4} = \frac{12 + 21.4 + 23.5 + 11.9}{4} = 17.2\%$$

$$P_{2000} = P_{1970} \left(1 + \frac{r}{100}\right)^n$$

$$\begin{aligned}
 (b) \quad r &= (r_1 r_2 r_3 r_4)^{1/4} \\
 &= (12 \times 21.4 \times 23.5 \times 11.9)^{1/4} \\
 &= 16.37\%
 \end{aligned}$$

So,

$$\begin{aligned}
 P_{2000} &= 47000 \left(1 + \frac{16.37}{100}\right)^3 \\
 &= 74066.62 \approx 74067
 \end{aligned}$$

(iii) Incremental Increase method :

$$\begin{aligned}
 \bar{y} &= \frac{\sum \text{col}(s)}{3} = \frac{2000}{3} = 666.67 \\
 P_{2000} &= P_{1970} + n\bar{x} + \frac{n(n+1)}{2}\bar{y} \\
 &= 47000 + 3 \times 5500 + \frac{3(3+1)}{2} \left(\frac{2000}{3}\right) \\
 &= 67500
 \end{aligned}$$

*Ans.*

## 1.4 | WATER RESOURCES

Mainly there are two types of water resources:

1. Surface water resources
2. Ground water resources

### 1. Surface water resources

- ❖ It consist river, lake, water fall etc.
- ❖ Among all the surface water resources rivers are main.
- ❖ The source of water in river is either rain or melting of ice.

### 2. Ground water resources

- ❖ The main ground water resources are well and tube-well.
  - ❖ The possibility of ground water occurrence depends upon (a) Porosity (b) Permeability
- (a) **Porosity** : Indicates voids in which water will be accumulated.

(b) **Permeability** : It represent ability to pass water to itself. Only if permeability is large enough than only water can be taken out from the pores.

## 1.5 | DARCY'S LAW

As per Darcy the velocity of flow in soil is directly perposonal to hydraulic gradient.

$$\begin{aligned}
 \Rightarrow \quad V &\propto i \\
 \Rightarrow \quad V &= K i \\
 \Rightarrow \quad Q &= KiA
 \end{aligned}$$

Where,

$Q$  = Discharge rate

$i$  = Hydraulic gradient

$A$  = Area of flow

$K$  = Permeability of soil

⇒ In general

$$A = \pi d h$$

But, Area available for flow of the water is only void present in soil mass.

So,

$$A_{\text{actual}} = \eta A$$

where,

$\eta$  = Porosity

⇒ For the continuity equation,

$$VA = V_{\text{act}} A_{\text{act}}$$

$$V_{\text{act}} = V \left( \frac{A}{A_{\text{act}}} \right)$$

⇒

$$V_{\text{act}} = V_{\text{seepage}} = \frac{V}{\eta}$$

Co-efficient of permeability depends upon pores medium as well as fluid properties.

Co-efficient of permeability is given as

$$K = \frac{Cd^2g}{v}$$

where,

$C$  = shape factor

$v$  = kinematic viscosity of fluid

$g$  = gravity acceleration

$d$  = main or effective size of particle.

The component of permeability which represents only the properties of pores medium is called Intrinsic permeability / Absolute permeability. Given as

$$K_0 = Cd^2$$

$$K_0 = \frac{Kv}{2}$$

$$K_0 = \frac{K\mu}{r}$$

The unit of Intrinsic permeability is “m<sup>2</sup>” Or “Darcy”

$$1 \text{ darcy} = 9.87 \times 10^{-13} \text{ m}^2$$

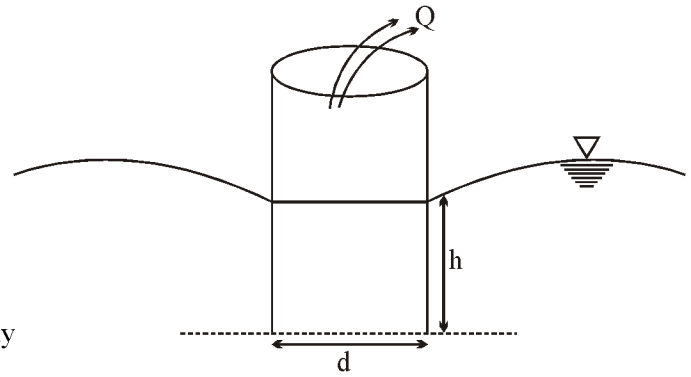

## 1.6 | TYPE OF GROUND LAYERS

On the basis of porosity and permeability the following types of layers are given.

1. *Aquifuse* : Neither pores nor permeable. *Example* : Granite.
2. *Aquitard* : Its permeability is less. It does not yield ground water freely, but seepage is possible through it.  
*Example* : sandy clay.
3. *Aquiclude* : Highly pores but not permeable. *Example* : Clayey soil.
4. *Aquifer* : High pores and enough permeable. *Example*: sand deposits

## 1.7 | GROUND WATER YEILD

All water in the pores cannot be drained out under gravity. Some water can be retain due to molecular attraction. It is called “Pellicular water”

$$\text{Specific yield} = \frac{\text{Volume of water drain out under gravity}}{\text{Total volume of soil being drain out}}$$

$$\text{Specific retention} = \frac{\text{Volume of water retain}}{\text{Total volume of soil being drain out}}$$

$$\boxed{\text{Specific yield} + \text{Specific retention} = \eta}$$

Smaller the particle size larger will be retention.

## 1.8 | SPECIFIC CAPACITY

It is a rate of flow from well per unit drawdown. *Various form of under ground source and there exploration:*

### 1. Infiltration Gallery

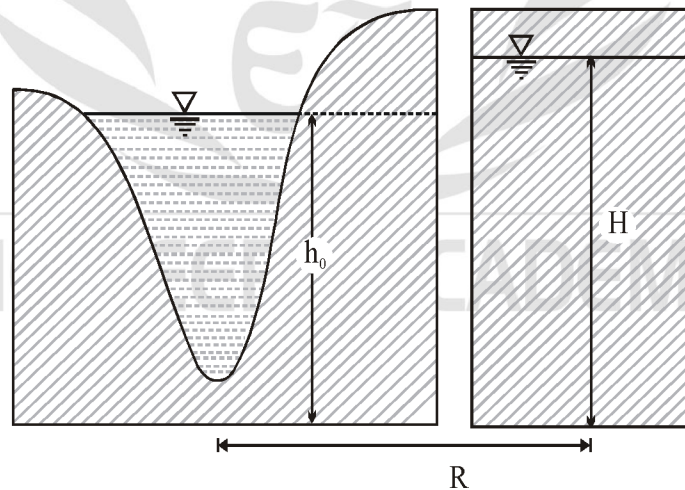

*infiltration gallery*

$$\text{Discharge } Q = \frac{K(H^2 - h_0^2)L}{R}$$

where,

K = Permeability of soil

H = Height of water table

$h_0$  = height of Infiltration gallery  
 $L$  = Length of Infiltration gallery  
 $R$  = Distance between water levels

2. Wells

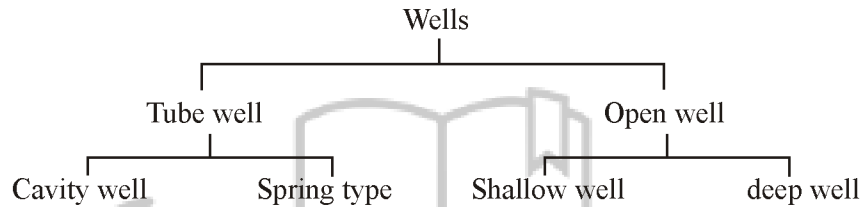
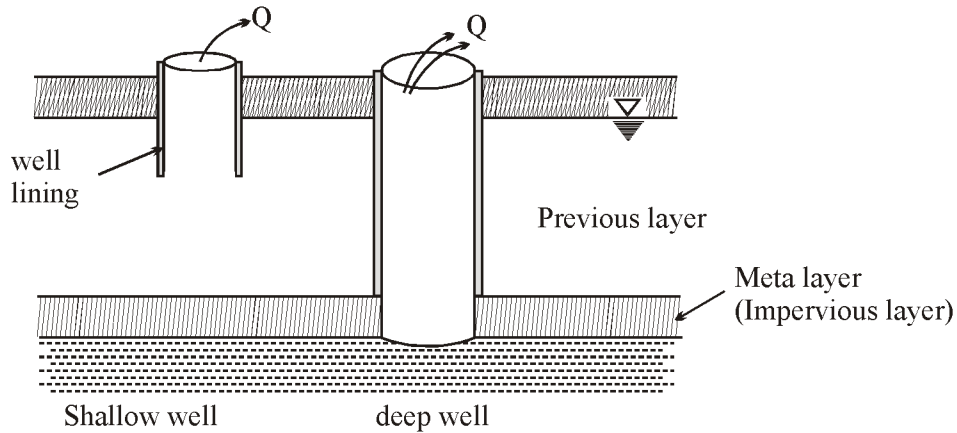

- **Shallow well** : Well lining are resisted by soil friction. It may be deeper than deep well.
- **Deep well** : Well lining rest on the first impervious layer.
- **Cavity Formation** : Due to large discharge from the deep well, upward velocity of flow become more than the critical velocity of flow and hence fine sand is get lifted along the water. More lifting of fine sand cause a cavity below the meta layer.
- It increase the flow area approx 4/3 times.
- Cavity formation is dangerous in shallow well, as well lining may sink. hence discharge from shallow well is limited.

1.9 | YIELD OF OPEN WELL

Yield at open well correctly calculated by pumping test in the field.

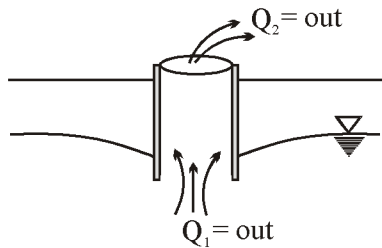

$Q_1 = Q_2$  = water level maintain  
 $Q_1 > Q_2$  = water level increases  
 $Q_1 < Q_2$  = water level decreases



**1.10 | PUMPING TEST**

Pumping causes drawdown thus it is adjusted to make water level constant. Under this equilibrium condition rate of pumping will be equal to rate of yield from the well

$$Q = CAS$$

where,

Q = Discharge

C = Specific capacity per unit area of well

S = Drawdown

A = Area of well (Bottom area)

$$= \frac{\pi}{4} d^2 \text{ (Shallow well)}$$

$$= \frac{4}{3} \times \frac{\pi}{4} d^2 \text{ (for deep well)}$$

If C and A are constant then

$$\frac{Q}{S} = \text{constant.}$$

$$\boxed{\frac{Q_1}{S_1} = \frac{Q_2}{S_2}}$$

The value of 's' for which the velocity become equal to critical velocity (for sand comes out) is called "Critical dispersion head". Working head =  $\frac{1}{3}$  critical dispersion head (generally).

□□□

## OBJECTIVE QUESTIONS

1. Consider the following statements:  
The daily per capita consumption of water apparently increase with
  1. higher standard of living of people
  2. availability of sewerage in the city
  3. metered water supply
  4. wholesome and potable quality of water
 Which of these statements are correct?
  - (a) 1, 2 and 3                      (b) 2, 3 and 4
  - (c) 1, 3 and 4                      (d) 1, 2 and 4
  
2. Water distribution systems are sized to meet the
  - (a) maximum hourly demand
  - (b) Average hourly demand
  - (c) maximum daily demand and fire demand
  - (d) average dialy demand and fire demand
  
3. The present population of a community is 28000 with an average water consumption of 4200 m<sup>3</sup>/d. The existing water treatment plant has a design capacity of 6000 m<sup>3</sup>/d. It is expected that the population will increase to 44000 during the next 20 years. The number of years from now when the plant will reach its design capacity, assuming an arithmetic rate of population growth, will be
  - (a) 5.5 years                      (b) 8.6 years
  - (c) 15.0 years                      (d) 16.5 years
  
4. On which of the following factors, does the population growth in a town normally depend?
  1. Birth and death rates
  2. Migrations
  3. Probabilistic growth
  4. Logistic growth
 Select the correct answer using the code given below:
  - (a) 1 and 4                      (b) 1 and 2
  - (c) 1, 2 and 3                      (d) 2 and 3
  
5. Which one of the following factors has the maximum effect on figure of per capita demand of water supply of given town?
  - (a) Method of charging of the consumption
  - (b) Quality of water
  - (c) System of supply-intermittent
  - (d) Industrial demand
  
6. In a city with a population of 70,000 water is drawn for domestic purposes from a bell-mouth intake in a canal which runs only for 10 hours a day with a flow depth of 1.5m. If the average consumption per person is 150 lpcd , then the intake load is
  - (a) 0.30 m<sup>3</sup>/s                      (b) 0.29 m<sup>3</sup>/s
  - (c) 0.27 m<sup>3</sup>/s                      (d) 0.25 m<sup>3</sup>/s
  
7. Which one of the following methods given the best estimate of population growth of a community with limited land area for future expansion?
  - (a) Aritmetical increase method
  - (b) Geometrical increase method
  - (c) Increamental increase method
  - (d) Logistic method
  
8. The averaging is done for per capita water demand is over a period of time
  - (a) 24 hours                      (b) One years
  - (c) 10 year                      (d) 35 years
  
9. The multiplying factor, as applied to obtain the peak hourly demand, in relation to the maximum daily demand (per hour) is
  - (a) 1.5                      (b) 1.8
  - (c) 2.0                      (d) 2.7
  
10. If the average daily water consumption of a city is 24000 cum, the peak hourly demand (or the maximum day) will be
  - (a) 1000 cum/hr                      (b) 1500 cum/hr
  - (c) 1800 cum/hr                      (d) 2700 cum/hr

11. Match List-I (Tests) with List-II (Features) and select the correct answer using the codes given below the lists:
- List-I**
- Pumping test
  - Recuperation Test
  - Pressure Test
  - Jar Test
- List-II**
- The gradual rise of water level in well is observed as time progresses
  - Rate of pumping is adjusted to constant level of water in well
  - Vigorous mixing of the chemical following by slow mixing.
  - Pipeline is filled up with water, allowed to stand for sometime and then at least double the maximum pressure is applied.
- Codes:**
- |     | A | B | C | D |
|-----|---|---|---|---|
| (a) | 1 | 2 | 3 | 4 |
| (b) | 2 | 1 | 4 | 3 |
| (c) | 1 | 2 | 4 | 3 |
| (d) | 2 | 1 | 3 | 4 |
12. Water treatment units may be designed, including 100% reserves, for water demand equal to
- Average daily
  - Twice of average daily
  - Maximum daily
  - None of the above
13. Distribution system in water supplies, is designed on the basis of
- Average daily demand
  - Peak hourly demand
  - coincident draft
  - Greater of (b) and (c) above
14. The average per capita consumption of water per day in an indian city is about
- 135 l
  - 300 l
  - 450 l
  - 600 l
15. Industrial and commercial demand accounts for...of the total demand
- 5%
  - 30%
  - 20%
  - 10%
16. Water is said to be contaminated, if it contain
- Pathogens
  - Undesirable suspended matter, making it unfit for drinking and domestic use
  - Dissolved salts
  - None of the above
17. 'Wholesome water' does not contain
- Pathogenic bacteria
  - Suspended matter in quantities harmful to man
  - Fire and public-use demand
  - All of the above
18. Industrial and commercial water demand in a city as compared to total demand of city, is
- 10 to 15%
  - 15 to 20%
  - 20 to 25%
  - 30 to 40%
19. Decrease in per capita consumption occurs by
- Use of metering system
  - Hot climate
  - Good quality water is supplied
  - All of the above
20. The population figures in a growing town are as follows:
- | Year | Population |
|------|------------|
| 1970 | 40,000     |
| 1980 | 46,000     |
| 1990 | 53,000     |
| 2000 | 58,000     |
- The predicted population in 2010 by Arithmetic Regression method is
- 62,000
  - 63,000
  - 64,000
  - 65,000

21. The population of a city in the year 2000 was 82,300. If average per cent increase in population per decade is 35%, the population of the city in the year 2020 estimated geometrical increase will nearly be
- (a) 1,00,000                      (b) 1,25,000  
(c) 1,50,000                      (d) 1,75,000
22. The population graph against time in arithmetical increase method is a
- (a) parabola                      (b) straight line  
(c) hyperbola                      (d) None of above
23. Turbidity measured on
- (a) standard silica scale  
(b) standard cobalt scale  
(c) standard platinum scale  
(d) None of these
24. The average domestic water consumption per capita per day for an Indian city, as per IS 1172-1963, may be taken as
- (a) 135 l/c/d                      (b) 210 l/c/d  
(c) 240 l/c/d                      (d) 270 l/c/d
25. The multiplying factor, as applied to obtain peak hourly demand, in relation to the average daily demand, (per hour), is
- (a) 1.5                              (b) 1.8  
(c) 2.0                              (d) 2.7
26. Coincident draft in relation to water demand, is based on
- (a) peak hourly demand  
(b) maximum daily demand  
(c) maximum daily + fire demand  
(d) greater of (a) and (c) above
27. The population of a town in three consecutive decades are : 1 lakh, 1.4 lakh, 1.68 lakh, respectively. The population of this town in the fourth consecutive decade, according to geometric method, would be
- (a) 1.9 lakh  
(b) 2.184 lakh  
(c) 2.2 lakh  
(d) 2.5 lakh

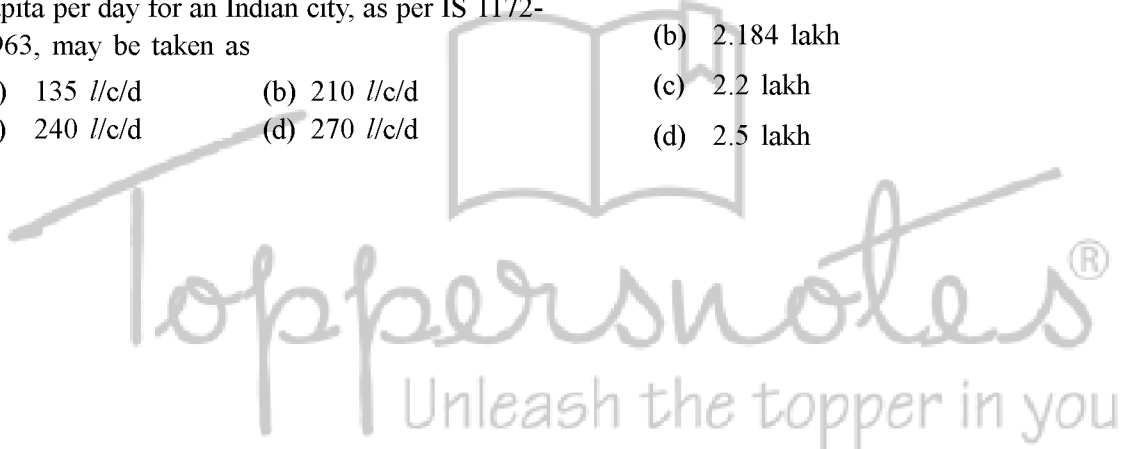

## ANSWERS AND EXPLANATIONS

1. *Ans. (d)*

To avoid wastage of water, the government sometimes uses metered water supply. As, in metered water supply, government can keep track amount of water used, it reduces the tendency of people to waste water. All the other statements increases the daily consumption of water.

2. *Ans. (d)*

3. *Ans. (c)*

$$P_0 = 28,000$$

Average increase per decade,

$$\bar{x} = \frac{44,000 - 28,000}{2} = 8,000$$

4200 m<sup>3</sup>/d required for 28,000 persons

6000m<sup>3</sup>/d sufficient for \_\_\_\_\_ persons

$$= \frac{28000 \times 6000}{4200} = 40,000$$

$$P_n = P_0 + n\bar{x}$$

$$40,000 = 28,000 + n.8,000$$

$$n = 1.5 \text{ decades}$$

$$= 15 \text{ years}$$

4. *Ans. (b)*

The population growth of a town depends mainly on three factors:

(i) Births.

(ii) Deaths.

(iii) Migration.

5. *Ans. (d)*

The pressure of industrial activity at a particular place increases the water consumption by large amounts. Many industries require huge amount of water (much more than the domestic demand) and as such, increase the water demand considerably.

6. *Ans. (b)*

$$\text{Population} = 70000$$

$$\text{Avg. consumption} = 150 \text{ lpd.}$$

$$\text{Total daily consumption} = \frac{70000 \times 150}{1000}$$

$$= 10500 \text{ m}^3/\text{day}$$

$$\text{intake load} = \frac{10500}{10 \times 60 \times 50}$$

$$= 0.29 \text{ m}^3/\text{sec.}$$

7. *Ans. (a)*

9. *Ans. (a)*

11. *Ans. (b)*

13. *Ans. (d)*

15. *Ans. (d)*

17. *Ans. (d)*

19. *Ans. (a)*

20. *Ans. (c)*

8. *Ans. (b)*

10. *Ans. (d)*

12. *Ans. (b)*

14. *Ans. (a)*

16. *Ans. (b)*

18. *Ans. (c)*

Year	Population	Increase
1970	40000	—
1980	46000	6000
1990	53000	7000
2000	58000	5000

∴ Average increase per decade

$$= \frac{6000 + 7000 + 5000}{3} = 6000 \text{ per decade}$$

Thus, in 2010 population will be

$$P_{2010} = 58000 + 6000 = 64000$$

21. *Ans. (c)*

$$P_{2020} = P_{2000} \left( 1 + \frac{R}{100} \right)^n$$

$$= 82300 \left( 1 + \frac{35}{100} \right)^2$$

$$= 149991.75 \approx 150000$$

22. *Ans. (b)*

24. *Ans. (a)*

26. *Ans. (c)*

23. *Ans. (a)*

25. *Ans. (d)*

27. *Ans. (b)*